

UNI-TILE12 C



max 12 mm



tile in
do płytek



architectural
architektoniczne

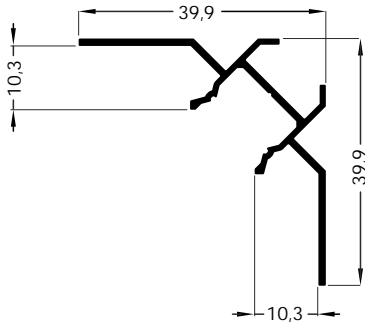

UNI-TILE12 90 deg/st C

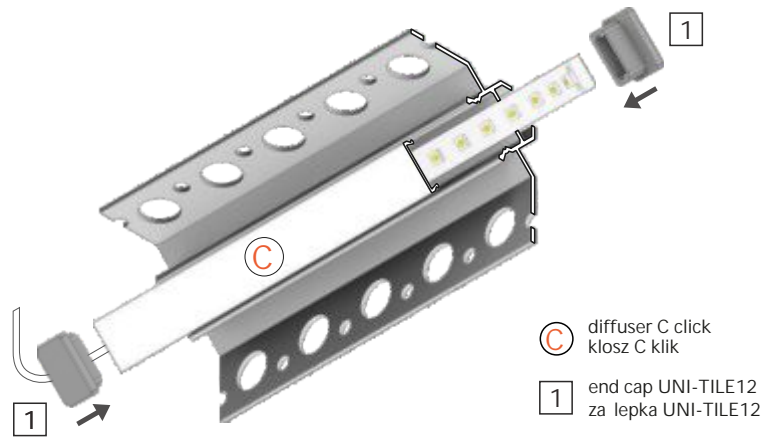
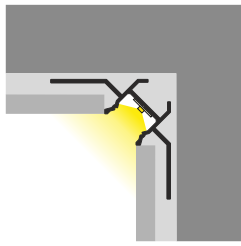

C diffuser C click
klosz C klik

1 end cap UNI-TILE12
za lepka UNI-TILE12

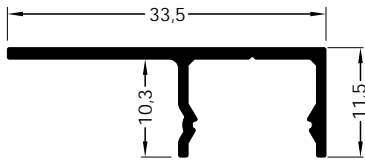

UNI-TILE12 180 deg/st C

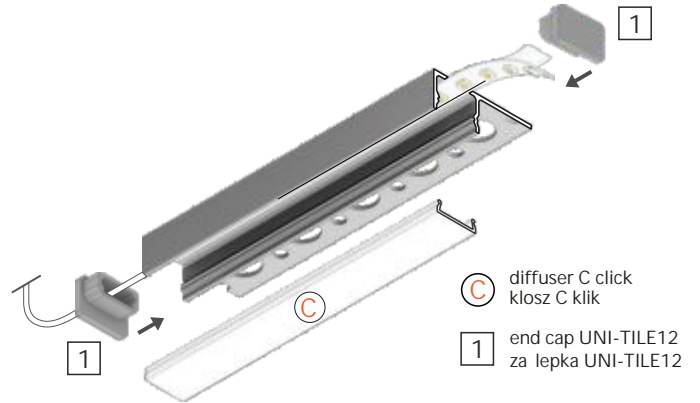

C diffuser C click
klosz C klik

1 end cap UNI-TILE12
za lepka UNI-TILE12

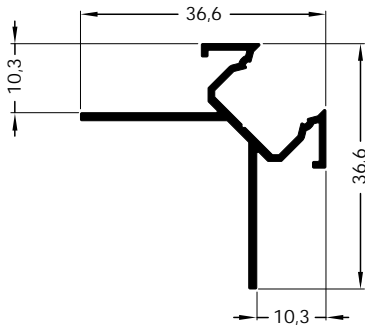

UNI-TILE12 270 deg/st C

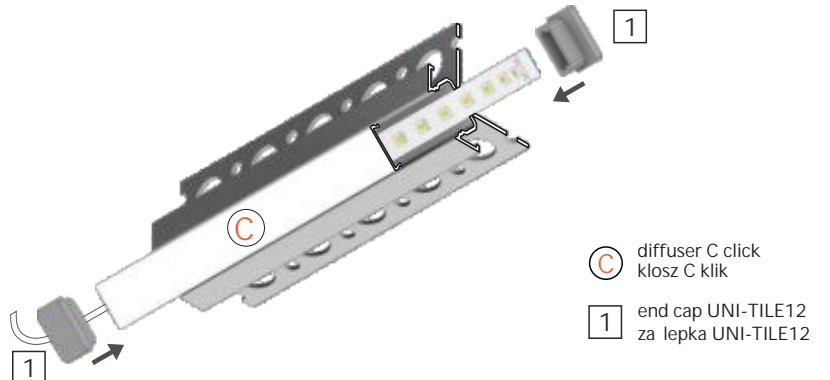
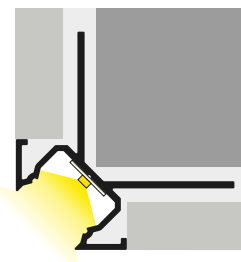

C diffuser C click
klosz C klik

1 end cap UNI-TILE12
za lepka UNI-TILE12



scissors
no yczki



hacksaw
piłka



pliers
kombinerki



solder
cyna



soldering iron
lutownica



screwdriver
wkr tak



glue
klej



drill
wiertarka

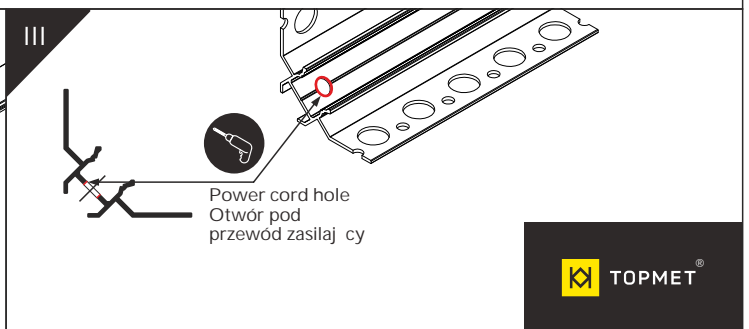
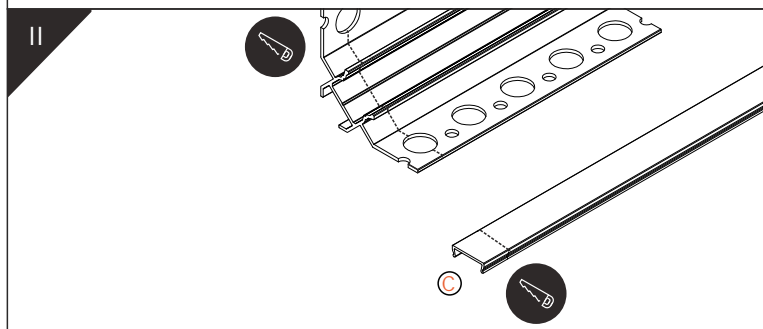
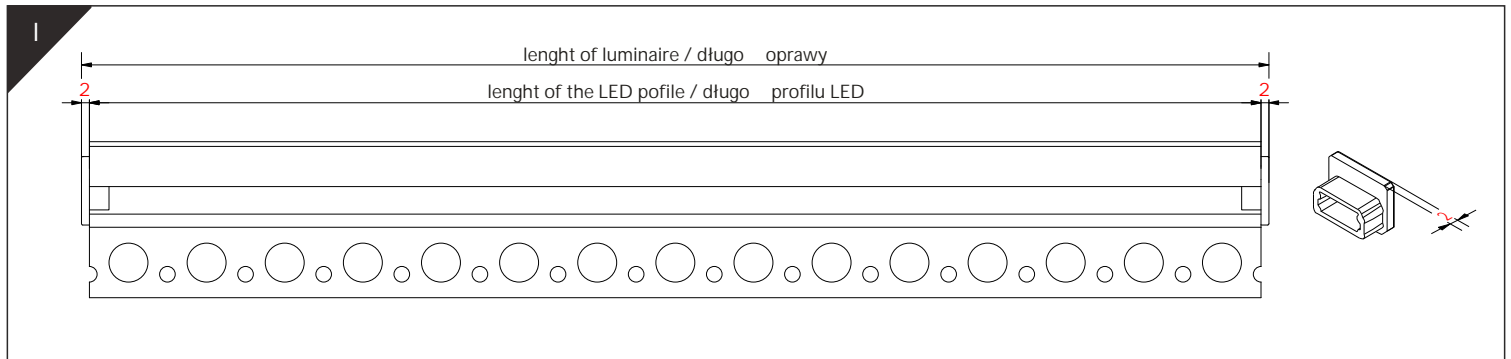

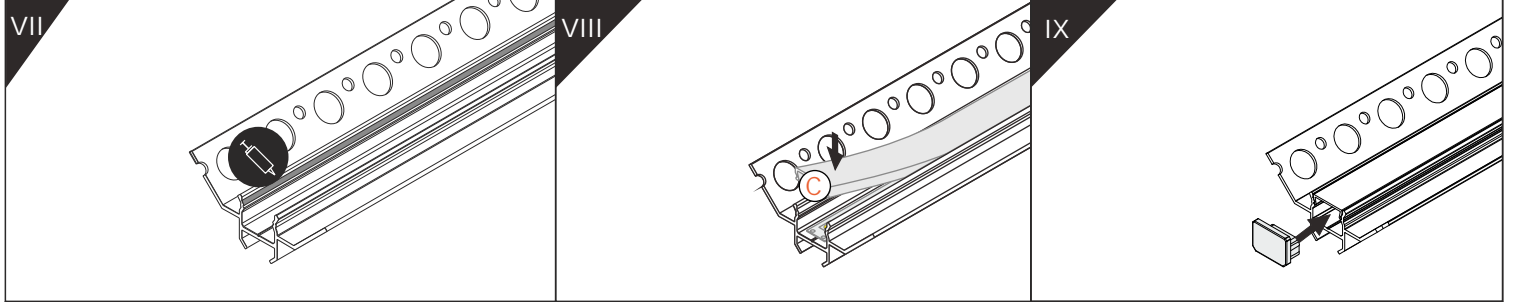
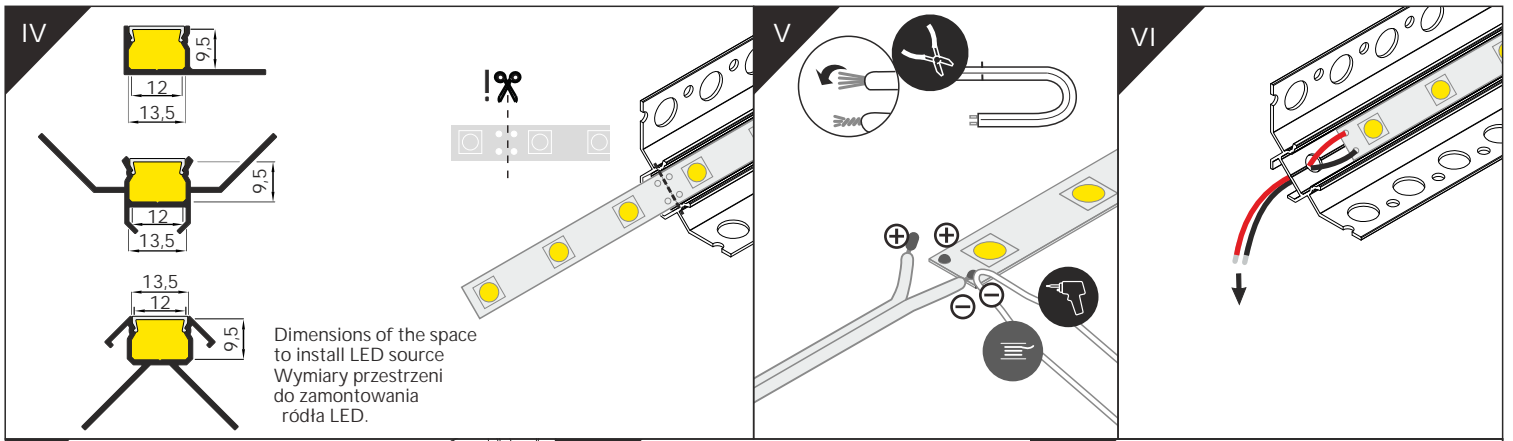

X MOUNTING / MONTA

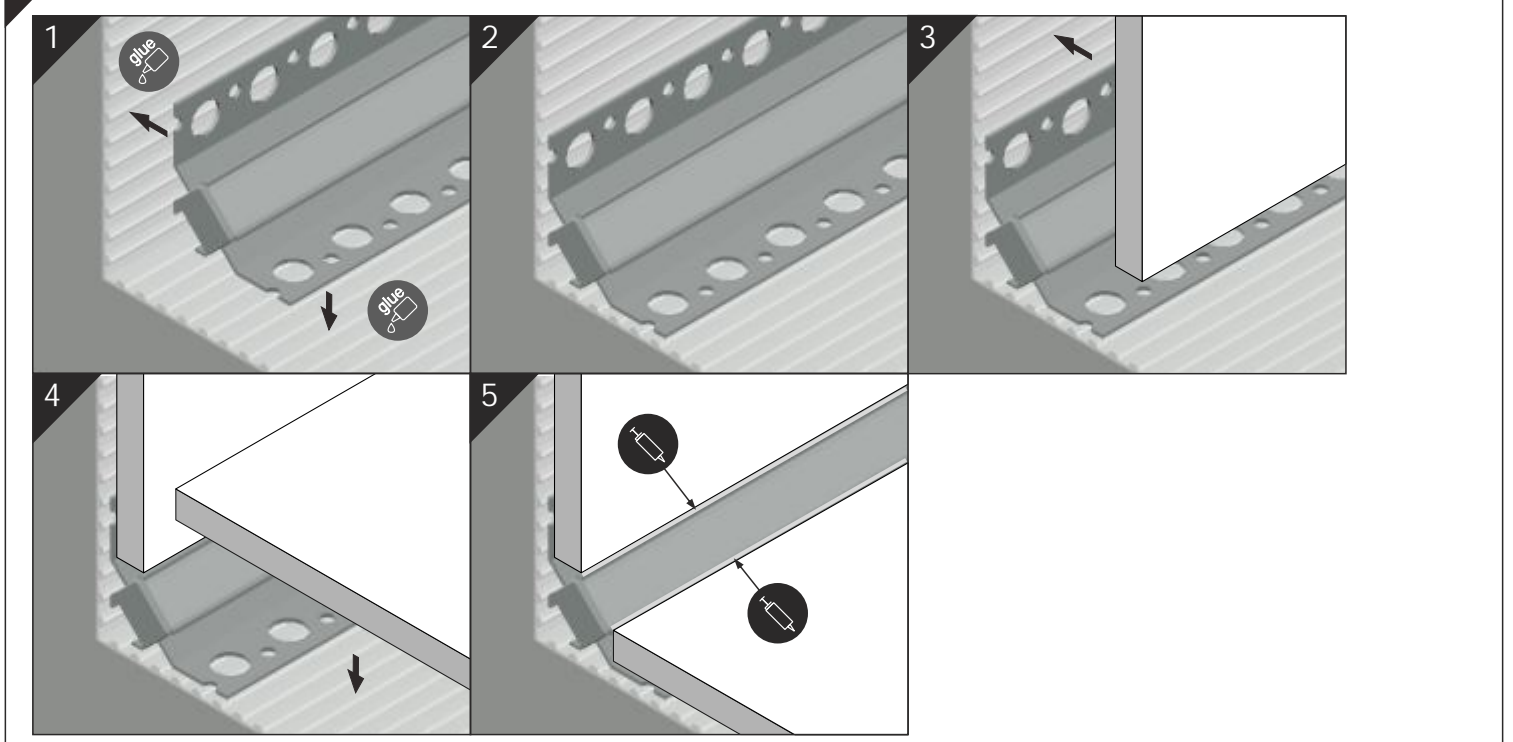

XI POWER SUPPLY / ZASILANIE

